

Microperforation system for tubers

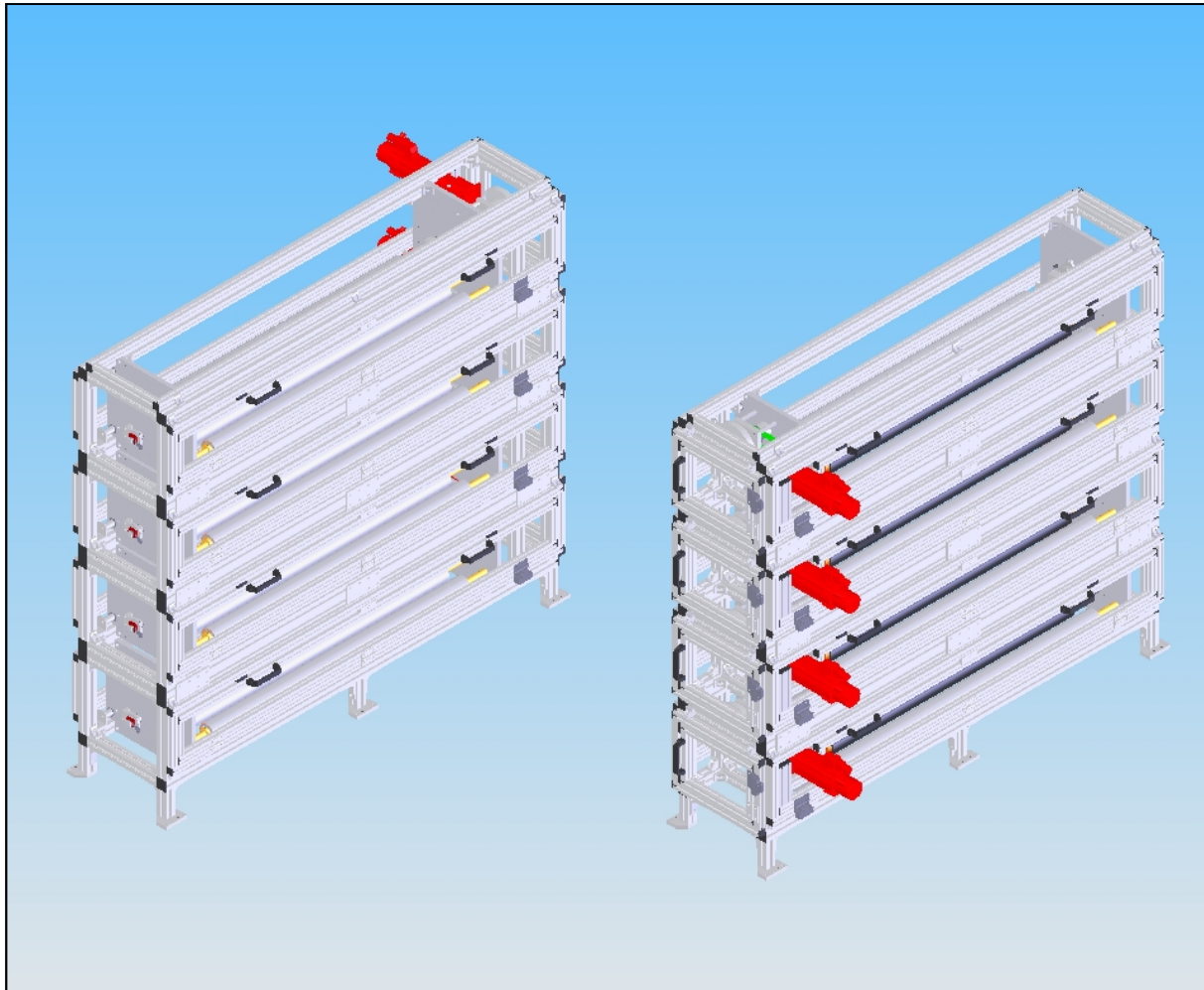

mawico automation systems

Gewerbestr. 10

D-77855 Achern-Önsbach

Tel: +49 7841 / 6065-0

Fax: +49 7841 / 6065-35

e-mail: info@mawico.com

web: www.mawico.com

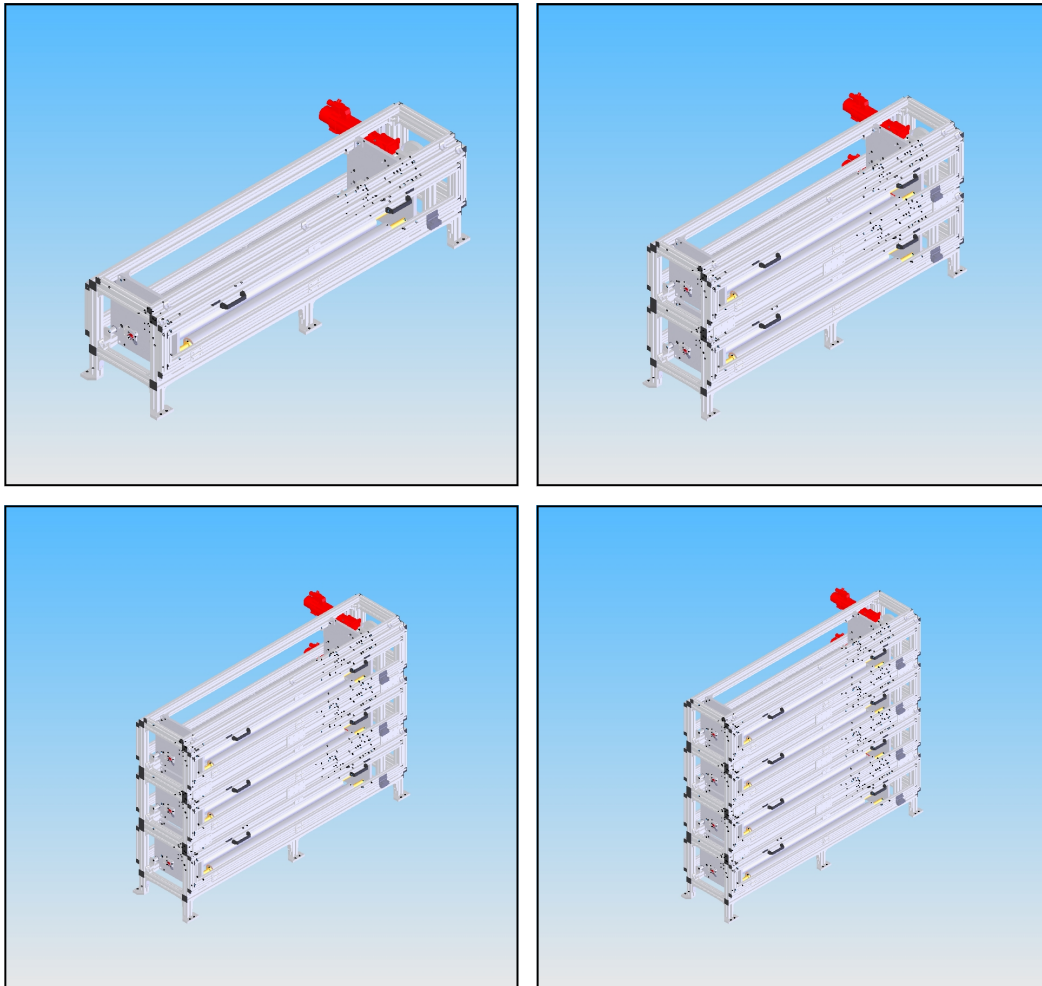

Features:

- separate frame for each station (upgradeable to max. 4 stations)
- individual skipping of the needle roller driven by servo gear motor for each station and simple cam for lifting (virtual cam simulated by the frequency converter for individual skipping)
- individual length and position of the skip-section on the tube format (input of the data by Touch-Display, different adjustments for each station possible)
- one needle and one brush roller for each station (brushes and needles are on sleeves for lateral adjustment on the roller)
- needle pattern according to customer requirements
- needle depth adjustable by eccentric supported brush roller
- inlet and outlet rollers for each station
- lateral adjustment of each station
- electrical equipment incl. PLC Siemens S7 and main cabinet
- connection to the tuber by an encoder for speed synchronization